



Aberdeen Boat Club

2012 Sunseeker Opening Regatta

Sailing Instructions

for

Dinghies

Saturday 1st and Sunday 2nd September 2012

The Regatta Organising Authority is the Aberdeen Boat Club under the auspices of the Hong Kong Sailing Federation. The Regatta Office will be at the Aberdeen Boat Club.

1. Rules

- 1.1 The Regatta will be governed by the 'rules' as defined in the *Racing Rules of Sailing 2009-2012* (RRS), the Prescriptions of the Hong Kong Sailing Federation, relevant Class Rules, the Aberdeen Boat Club (ABC) Sunseeker Opening Regatta Notice of Race and these Sailing Instructions, succeeding items of which take priority.
- 1.2 Non class-legal sails may be used provided they are of the correct dimensions.

2. Notices to Competitors

Notices to competitors will be posted on the Official Notice Board at ABC Middle Island Clubhouse.

3. Changes to Sailing Instructions

Any change to the sailing instructions will be posted on the ABC's Yachting Notice Board and on the Official Notice Board at ABC Middle Island Clubhouse before 0900 on the day it will take effect, except that any change to the schedule of races will be posted before 2000 hours on the day before it will take effect. This will be marked by an IC Flag "L" at the ABC Middle Island Clubhouse in daytime hours.

4. Signals Made Ashore

Signals made ashore will be displayed from the flagpole located at the ABC Middle Island Clubhouse.

5. Programme and Schedule of Races

5.1 The programme is as follows:

• Saturday 1 September	Competitors Briefing:	11.00
	Racing, first possible warning signal:	12.55
	Latest possible start:	16.00
• Sunday 2 September,	Competitors Briefing:	9.30
	Racing, first possible warning signal:	11.15
	Latest possible start:	16.00

5.2 Any number of races may be sailed each day, subject to the Race Officers discretion, aiming for a minimum of 5 races for the regatta. 3 races will constitute a series. The starts for each day's subsequent races will follow as soon as possible after completion of the previous race.

6. Class Flags

Class Flags will be:

Open Division A	"E" flag
Open Division B	"U" flag
Division C, Optimists:	"Q" flag
Division D, 29ers:	"V" flag

7. Racing Areas

The racing areas will be selected from around Middle Island, Repulse Bay, Chung Hum Kok Bay or Stanley Bay. Attachment A shows the location of the racing areas and this will be notified to competitors by the race committee hoisting signals ashore using the appropriate flag not less than 90 minutes before the first warning signal of the day.

Area G (Green Flag)	Area Outside Middle Island / Repulse Bay
Area Y (Yellow flag)	Chung Hom Kok
Area R (Red Flag)	Stanley Bay

8. The Courses

Courses will be chosen from those shown in Attachment B, and will be signalled by flags flown on the Race Committee Boat indicating the division and course.

9. Marks

Race marks are detailed in the Course diagram, attachment B. The compass bearing from the start line to the first mark may be displayed on a black or white board on the race committee boat

10. The Start

- 10.1 The Race Committee Boat will fly a blue flag when on station.
- 10.2 The start line will be between a signal mast displaying an orange flag on the committee boat and an Outer Distance Mark (ODM).
- 10.3 An Inner Distance Mark (IDM) may be laid at the starting line and, if laid, boats shall start by passing between the IDM and ODM in the direction of the first mark of the course.

11. The Finish

The finish line will be between a staff or mast displaying an orange flag on the committee boat and the nearby finish mark.

12. Penalty System

- 12.1 Rule 44.1 is changed so that the Two-Turn Penalty is replaced by the One -Turn Penalty.
- 12.2 Exoneration Penalty
 - 12.2.1 A boat that may have broken a rule may, after finishing the race concerned and before the start of a related protest hearing, notify the Race Committee that she accepts a 20% scoring penalty, except the minimum scoring penalty shall be 3 places. This changes Rule 44.3(c).
 - 12.2.2 The Exoneration Penalty is not available for a breach of Rule 2 or of class rules or for gross misconduct under Rule 69. Nor is it available to a boat that caused injury or serious damage, or gained a significant advantage by her breach of the rules:
 - 12.2.3 When an Exoneration Penalty is accepted,
 - a) neither the boat nor the Protest Committee may then revoke or remove the penalty
 - b) the boat shall not be penalised further in a protest hearing when the Protest Committee decides that the exoneration penalty was appropriate to the facts found and the appropriate rules.

13. Time Limits

- 13.1 The time limit for the first boat in each division to sail the course and finish shall be 60 minutes.
- 13.2 Boats failing to finish within 20 minutes after the first boat (Divisions A, B and C) and 10 minutes Division D) sails the course and finishes will be scored Did Not Finish (DNF) unless the Race Office finishes them on the water as set out in paragraph 10.3 below. This changes RRS rules 35 and A4.
- 13.3 When more than half the boats have finished the Race Office may finish the balance of the boats at the last mark, or on the course. The method of finishing and the finish positions awarded each boat thereby will be determined by the Race Officer on behalf of the race committee. This changes RRS rule 28.

14. Protests and Requests for Redress

Protests or request for redress must be lodged to the Protest Box at the bar of the ABC Middle Island Clubhouse within 90 minutes after the last boat has finished the last race of the day. A fee of HK\$200 will be charged with the submission of each protest or request for redress. The protest time limit will be posted on the Official Notice Board as soon as possible. The list of protests or requests for redress received and Hearing Schedule will be posted on the Official Notice Board, within 15 minutes of the end of Protest Time and a red flag will be hoisted on the club's flagpole. Hearings will be held as soon as possible after racing each day at the ABC's Middle Island clubhouse.

15. Scoring

15.1 Results in Open Divisions A and B will be calculated on corrected time using RYA PY handicaps, and results in Level Rating Division C, Optimists, and Division D, 29ers, will be based on finishing time over the finish line.

15.2 The Low Point Scoring System of RRS Appendix A will be used.

15.3 Rule A2 is changed as follows:

When four or fewer races have been completed, a boat's series score will be the total of her race scores.

When five races or more have been completed, a boat's series scores will be the total of her race scores excluding her worst score.

16. Registration & Safety

16.1 Competitors shall sign in / sign out on the registration sheets at ABC Middle Island Race Office. Failure to sign in or back out after the race may result in penalty or disqualification, at the discretion of the Race Committee. This changes rules A4 & A5.

16.2 Personal floatation devices (PFD's) in good serviceable condition shall be worn at all times while on the water during the regatta

16.3 Competitors are reminded of RRS Rule 4, Decision to Race.

17. Official Boats

Race Control boats will display a white flag.

18. Support Boats

Team leaders, coaches and other support personnel shall stay clear outside areas where the dinghies are racing from the time of the warning signal for the first class to start until all boats have finished or retired or the race committee signals a postponement, general recall or abandonment.

19. Trash Disposal

Boats shall not put trash in the water. Trash may be placed aboard support and race committee boats.

20. Prizes

Prizes will be awarded each day of the Regatta at 1830 at the ABC Middle Island Clubhouse.

21. Disclaimer of Liability

Participants compete entirely at their own risk; see RRS 4, Decision to Race. The Organising Authority, Regatta volunteers, the Aberdeen Boat Club and its officers, members and employees, Regatta sponsors and their representatives, officers, and members, accept no liability whatsoever for any loss of life or property, personal injury and damage caused by, or arising out of the Regatta.

22. Entries, Further Information & enquiries

Enquires and entries should be addressed to:

Aberdeen Boat Club Ltd.,

20 Shum Wan Road, Aberdeen,

Hong Kong

Telephone: 2553 3032

Email: mbs@abclubhk.com or sailingsecretary@abclubhk.com

Fax No: *Fax:* 2873 2945

Website www.abclubhk.com



Attachment A
Sailing Areas

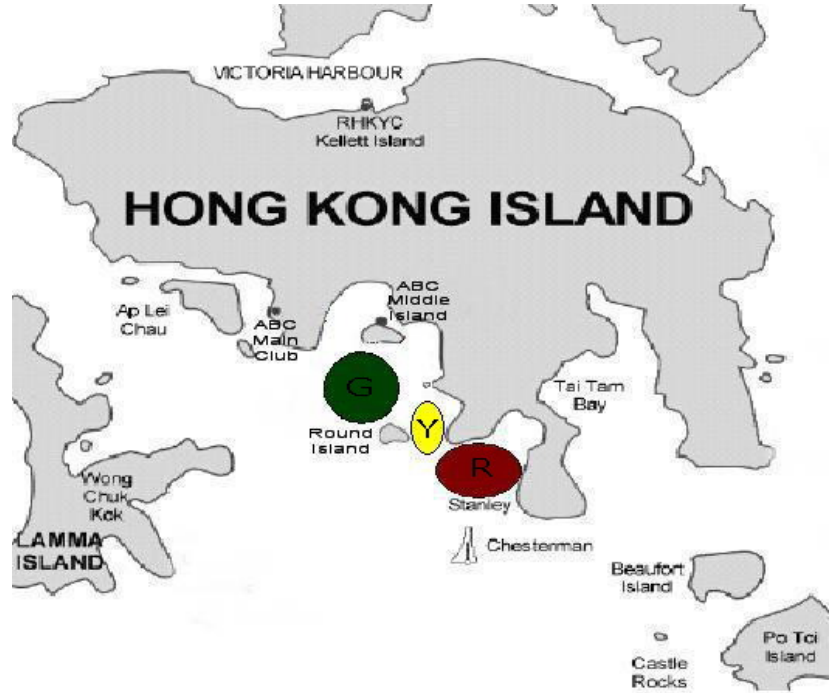



Attachment B

Courses

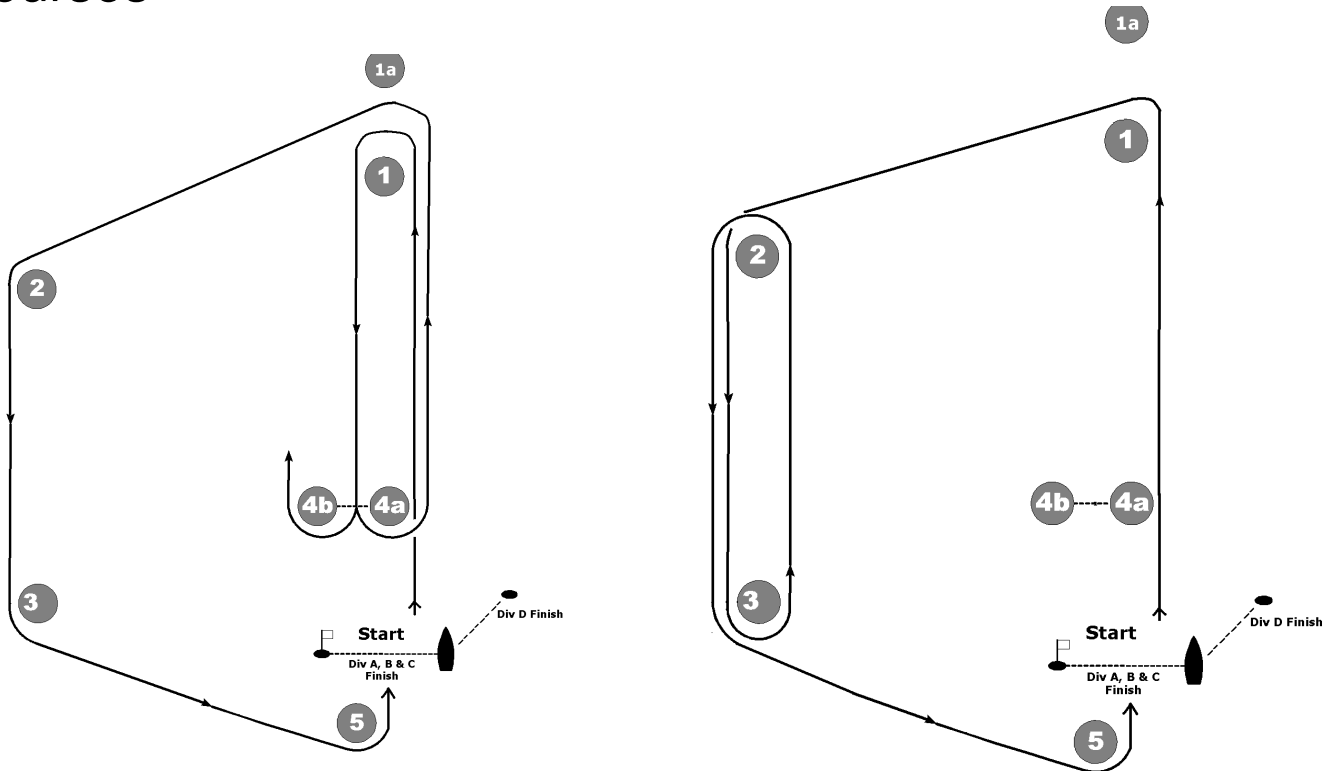

Marks 1, 2, 3, 5 will be large black buoys

Marks 4a, 4b, 1a will be large yellow buoys

The start / finish buoy for all div A, B and C will be a small buoy with a flag,
the finish for div D will be a a round pink buoy

<p>Course 1 Start, 1, 4a/4b, 1, 2, 3, 5, Finish ("Inner loop")</p>	<p>Course 4 Start, 1, 2, 3, 2, 3, 2, 3, 5, Finish ("double outer loop")</p>
<p>Course 2 Start, 1, 4a/4b, 1, 4a/4b, 1, 2, 3, 5, Finish ("double inner loop")</p>	<p>Course 5 Start, 1a, 4a/4b, 1a, 4a/4b, Finish (Div D) ("double windward-leeward")</p>
<p>Course 3 Start, 1, 2, 3, 2, 3, 5, Finish ("outer loop")</p>	<p>Course 6 Start, 1, 2, 3, 5, Finish ("circuit")</p>